



LOOK OUT BILLY!

SCREEECH

I'VE GOT IT!

OH NO-!

BOING



THAT DIDN'T SOUND GOOD, TUCKER!

I HOPE EVERYONE'S OKAY!

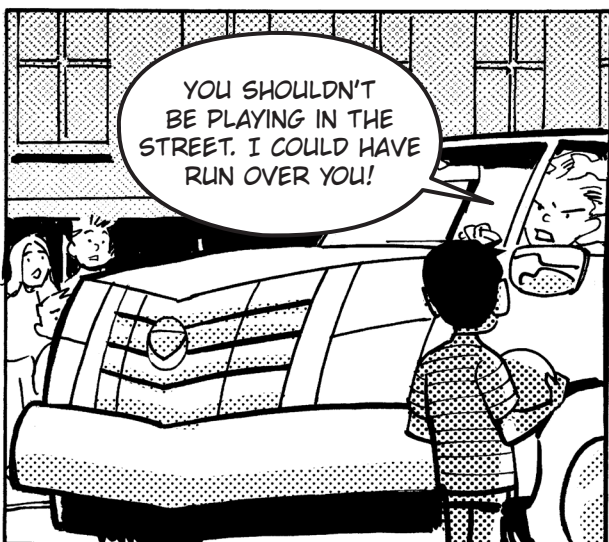

YOU SHOULDN'T BE PLAYING IN THE STREET. I COULD HAVE RUN OVER YOU!

WE SHOULD JUST SOLVE THIS PROBLEM ONCE AND FOR ALL.

I THINK WE HAVE TO INVENT THE SOLUTION, IN A BIGGER WAY THAN WE EVER HAVE BEFORE. THIS NEIGHBORHOOD NEEDS A -

PRESENTED BY **HOWTOONS** AND **THE LEMELSON-MIT INVENTEAMS.**

PLAYGROUND

WRITTEN BY JEFF PARKER, ART BY SANDY JARREL, EDITS BY LEIGH ESTABROOKS



NOW, IF WE INVENT OUR OWN PLAYGROUND, WHAT COULD IT HAVE?

WHAT WOULDN'T IT HAVE? IT COULD BE THE MOST AWESOME PLAYGROUND IN HISTORY!

TIME TO DO SOME FIELD RESEARCH AND CHECK OUT SOME PLAYGROUNDS!

THE BEST EXCUSE EVER TO GO AND PLAY!

"FIRST LET'S INTERVIEW SOME USERS".

WHAT DO YOU WANT IN A PLAYGROUND?

A SPACE FOR THE FAMILY TO SIT.

A PLACE TO CLIMB!

I AM GOING TO TAKE SOME PICTURES OF SOME GREAT PLAYGROUND FEATURES.

I'LL SKETCH OUT IDEAS!

HERE ARE A COUPLE OF WAYS TO BUILD SOME OF OUR IDEAS.

PLAYGROUND D.I.Y.

STABLE PLAY STRUCTURE

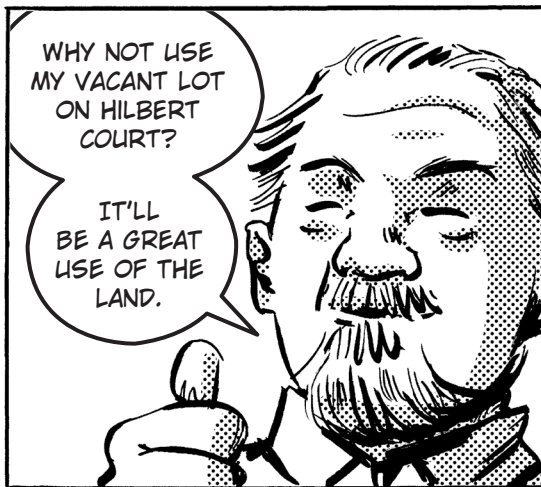

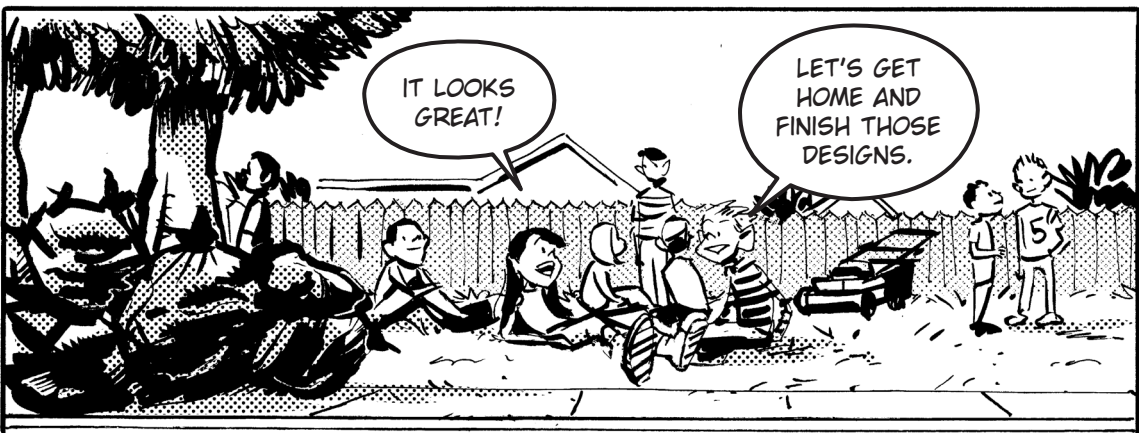

LATER... AN EVENING OF FURIOUS BRAINSTORMING AND RE-IMAGINING!

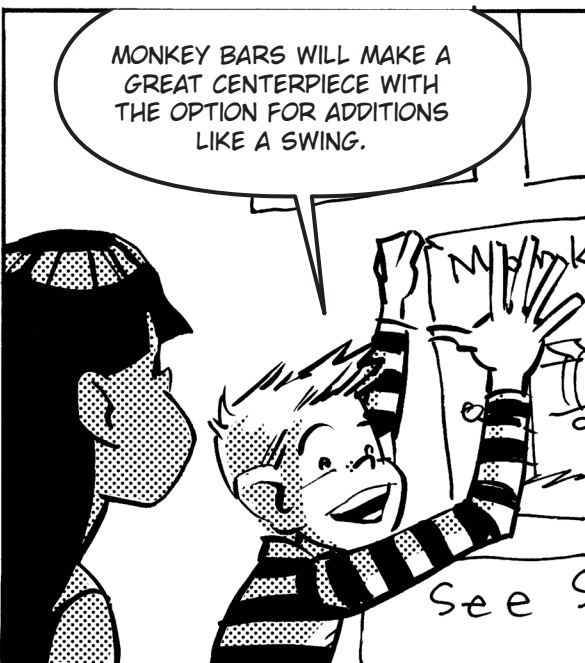
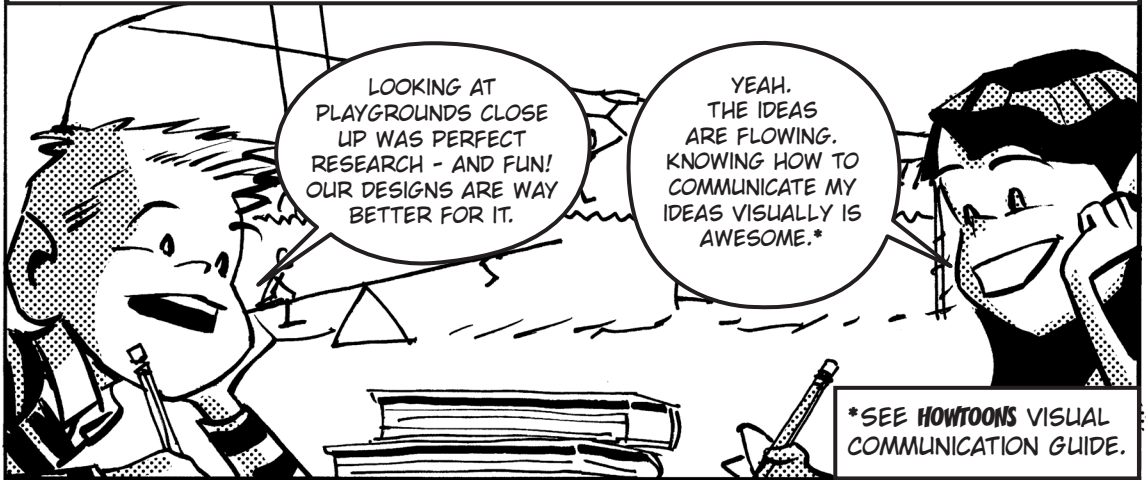

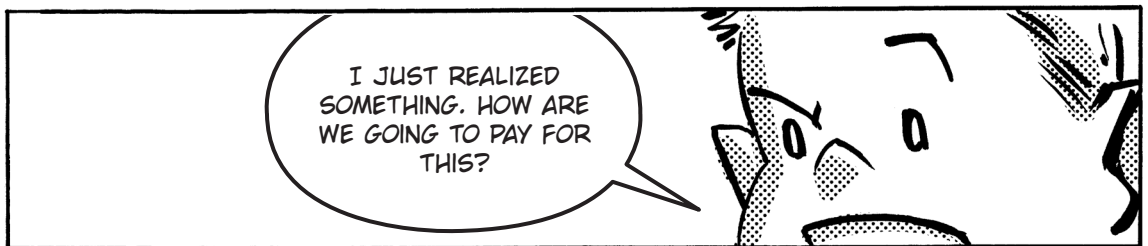
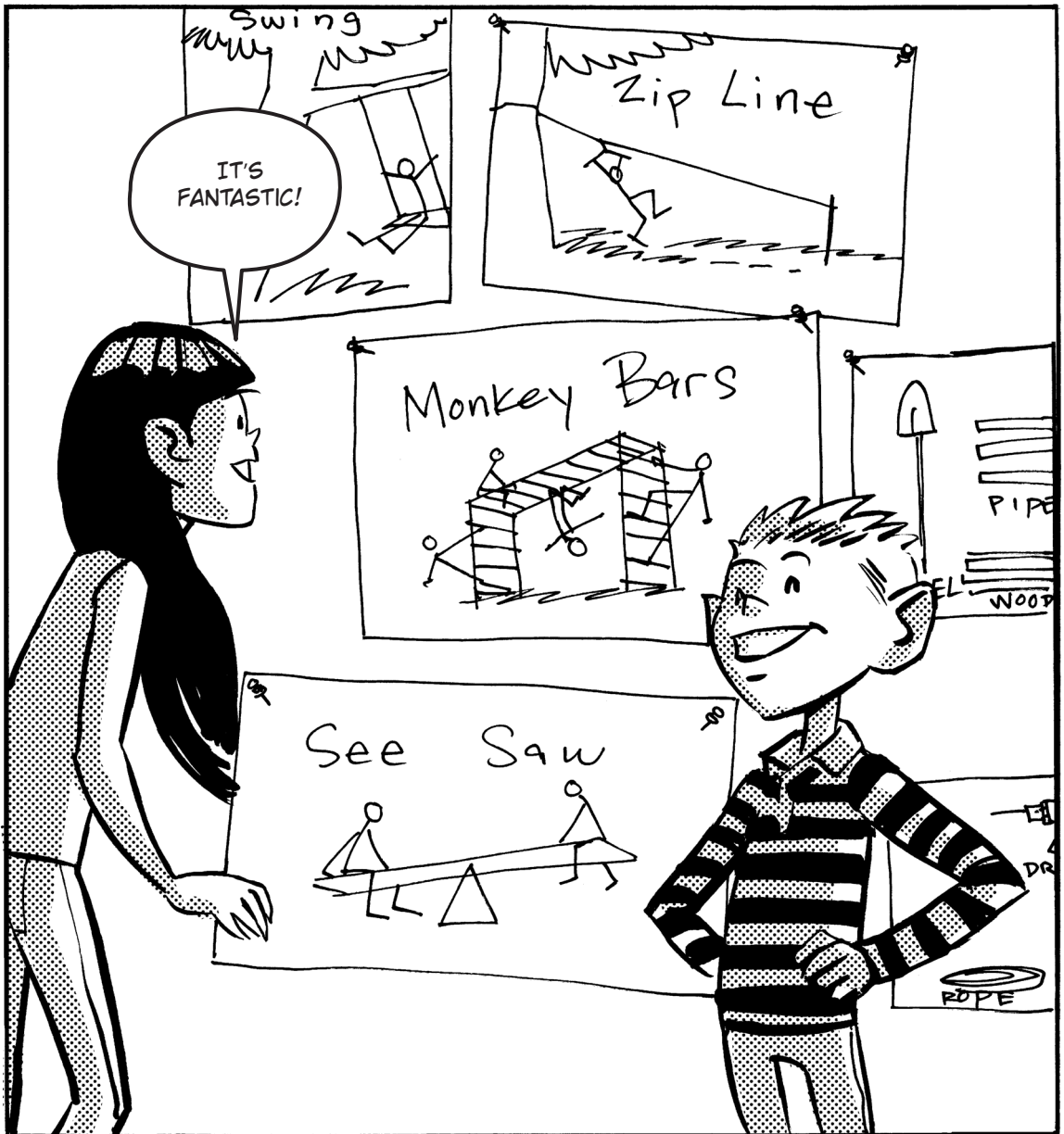

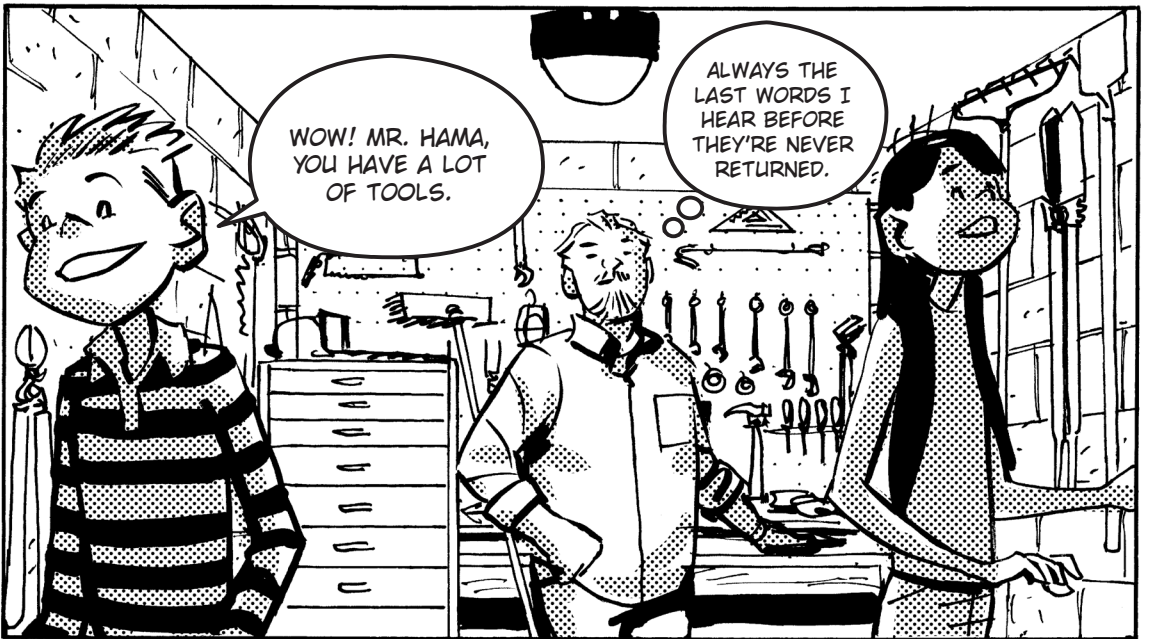

TOOL SAFETY!



A FEW WORDS TO REMIND YOU TO STAY SAFE.

FIRST, DON'T BE IN A RUSH! ACCIDENTS HAPPEN WHEN YOU GO TOO FAST.



BRING A PARENT OR GUARDIAN!

YOUR PROJECT NEEDS ADULT SUPERVISION!

I'M HERE TO HELP.



CERTIFIED PROTECTIVE EYEWEAR IS A MUST!

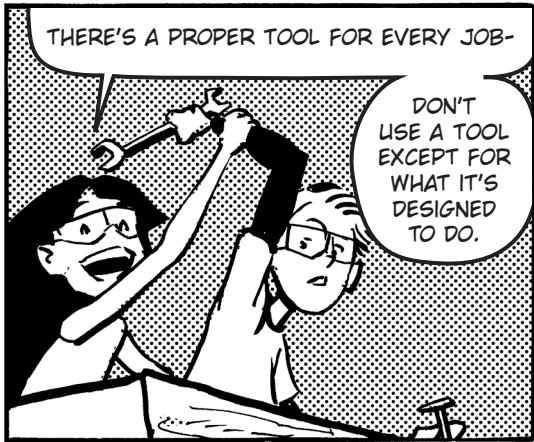

THERE'S A PROPER TOOL FOR EVERY JOB-

DON'T USE A TOOL EXCEPT FOR WHAT IT'S DESIGNED TO DO.



PROTECT YOUR HANDS WITH THICK WORK GLOVES!

BUT MAKE SURE THEY STILL LET YOU MOVE YOUR FINGERS.

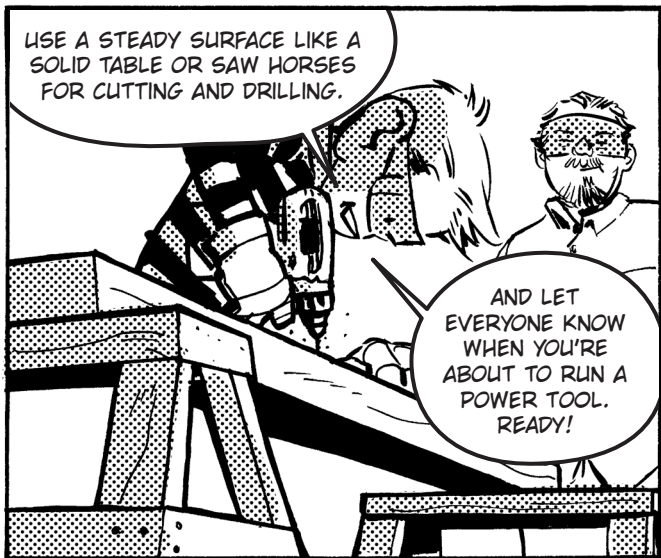

USE A STEADY SURFACE LIKE A SOLID TABLE OR SAW HORSES FOR CUTTING AND DRILLING.

AND LET EVERYONE KNOW WHEN YOU'RE ABOUT TO RUN A POWER TOOL. READY!



GIVE MOTORS A CHANCE TO COOL DOWN - RUNNING A POWER TOOL TOO HARD CAN OVERHEAT IT...

... DAMAGING THE EQUIPMENT AND MAYBE YOU.

DRILL HOLES AND DRIVE SCREWS WITH THE...

DRILL

CHUCK: IS THE CLAMP THAT HOLDS THE DRILL BIT. LEFTY LOOSEY (COUNTER-CLOCKWISE) TO LOOSEN THE CHUCK. RIGHTY TIGHTY (CLOCKWISE) TO TIGHTEN.



HOLD DRILL

PERPENDICULAR TO WORK TO KEEP THE HOLE STRAIGHT.

PILOT HOLE: ON REALLY TOUGH MATERIALS, MAKE A PILOT HOLE WITH A SMALLER BIT FIRST, AND THEN INCREASE THE SIZE OF THE BITS TO GET TO THE DIAMETER YOU NEED.

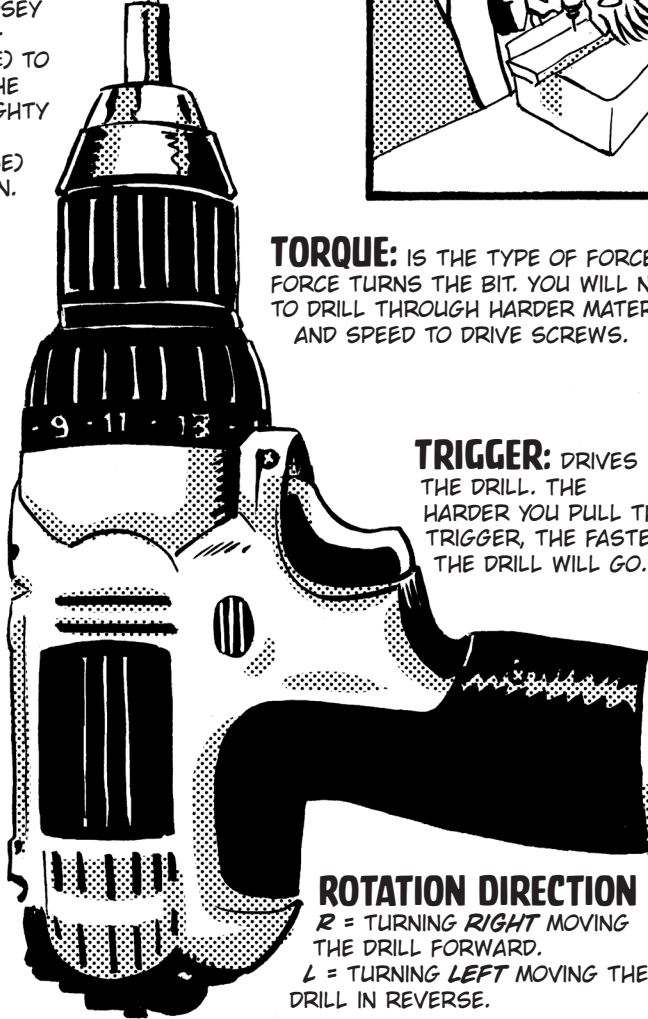
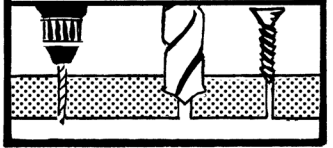

TORQUE: IS THE TYPE OF FORCE PRODUCED BY A DRILL. THIS FORCE TURNS THE BIT. YOU WILL NEED MORE TORQUE AND SPEED TO DRILL THROUGH HARDER MATERIAL. YOU WANT LOW TORQUE AND SPEED TO DRIVE SCREWS.

TRIGGER: DRIVES THE DRILL. THE HARDER YOU PULL THE TRIGGER, THE FASTER THE DRILL WILL GO.

ROTATION DIRECTION







R = TURNING RIGHT MOVING THE DRILL FORWARD.
L = TURNING LEFT MOVING THE DRILL IN REVERSE.

BATTERY

DRILL BITS

CHOOSE THE DRILL BIT FOR THE JOB AND MATERIAL.

DRILLS CAN DO OTHER THINGS, TOO.

<p>TWIST BIT</p>  <p>GENERAL PURPOSE</p>	<p>SPUR POINT</p>  <p>WOOD</p>	<p>STEEL BIT</p>  <p>METAL</p>	<p>MASONRY</p>  <p>STONE, BRICK, CONCRETE</p>	<p>SPADE BIT</p>  <p>LARGE HOLES IN WOOD</p>	<p>PHILLIPS</p>  <p>SCREWDRIVER ATTACHMENT</p>	<p>HOLE SAW</p>  <p>WOOD OR PLASTIC</p>
--	--	--	---	--	---	---



THIS TREE LOOKS HEALTHY AND HAS STRONG BRANCHES. IT WOULD BE GREAT FOR A SWING!

GET STARTED
TIME TO GET TO WORK! PICK THE SIMPLEST PROJECT FIRST SO YOU CAN SEE RESULTS FASTER, AND BUILD YOUR SKILLS AS YOU GO.

- MATERIALS AND TOOLS:**
- CIRCLE OF WOOD 1 1/2" X 12"
 - 50 FEET OF ROPE AT LEAST 1/4" THICK
 - DRILL
 - CLAMPS

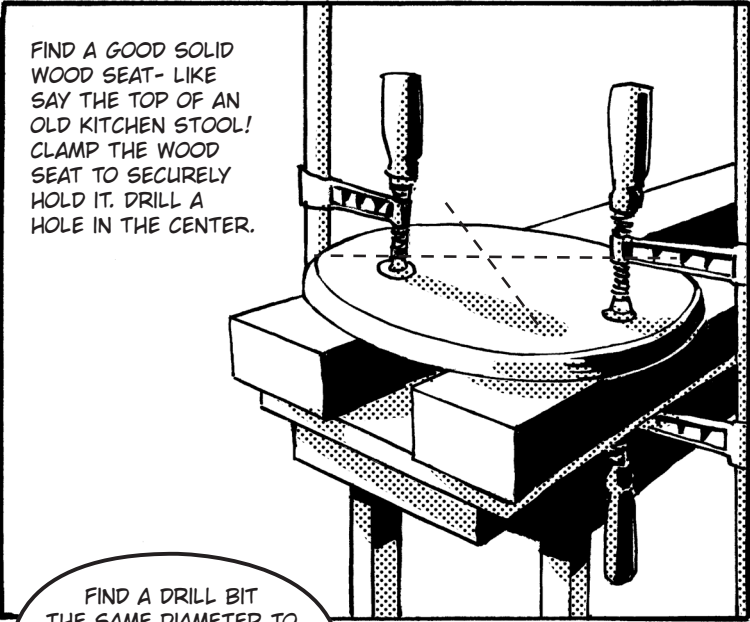

FIND A GOOD SOLID WOOD SEAT- LIKE SAY THE TOP OF AN OLD KITCHEN STOOL! CLAMP THE WOOD SEAT TO SECURELY HOLD IT. DRILL A HOLE IN THE CENTER.

FIND A DRILL BIT THE SAME DIAMETER TO MATCH THE THICKNESS OF THE ROPE. USE A SPADE BIT OR A HOLE SAW.

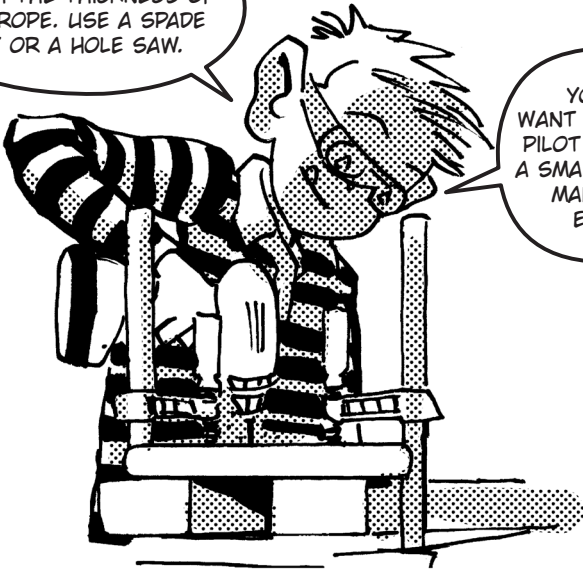

YOU MAY WANT TO START A PILOT HOLE WITH A SMALLER BIT TO MAKE IT GO EASIER.



TO FIND THE LENGTH OF THE ROPE, MEASURE THE DISTANCE OF THE BRANCH TO THE GROUND AND DOUBLE THE AMOUNT OF ROPE.

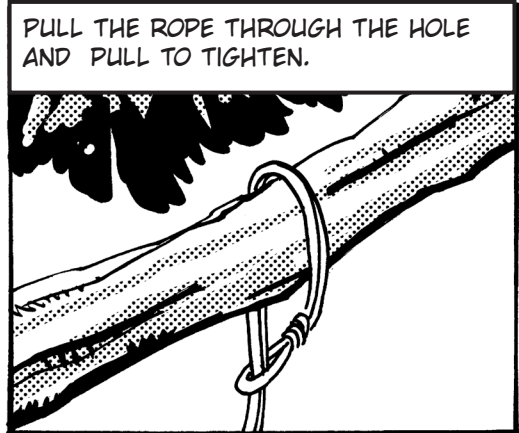
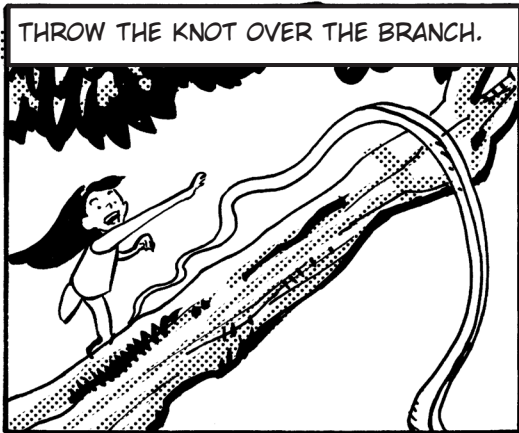
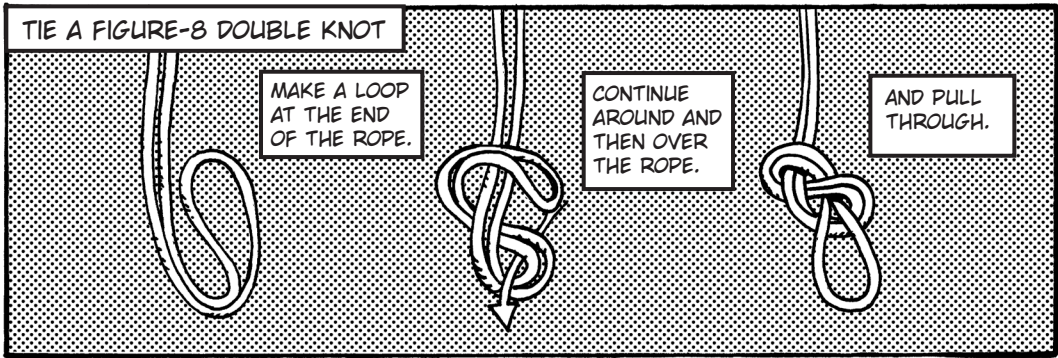

YOUR OWN WEIGHT WILL CINCH THE KNOT!



IT SEEMS LIKE WE SHOULD SAY SOMETHING ELSE HERE... OH YEAH.

WHEEE!!

NEXT... →

LET'S BUILD A

ZIP LINE!

THIS LOOKS LIKE A GREAT SPOT TO PUT OUR ZIPLINE. NOT TOO MUCH INCLINE AND THE LAND IS FLAT AND FREE OF DEBRIS!



MATERIALS:

ZIPLINE:

- 1/4" GALVANIZED WIRE CABLE (MEASURE BETWEEN TREES FOR LENGTH)
- 1 1/4" ALUMINUM WIRE SWAGE
- 3 1/4" CABLE CLAMPS
- 2 RATCHET STRAPS
- 2 QUICK LINK
- LADDER

HANDLE:

- 2 WHEEL PULLEY
- STEEL CARABINER
- HANDLE BARS

SAFETY:

- 4"X4"X6": WOODEN BLOCK
- 20 FT BUNGEE CORD
- 6" EYELET BOLT
- SAND OR MULCH

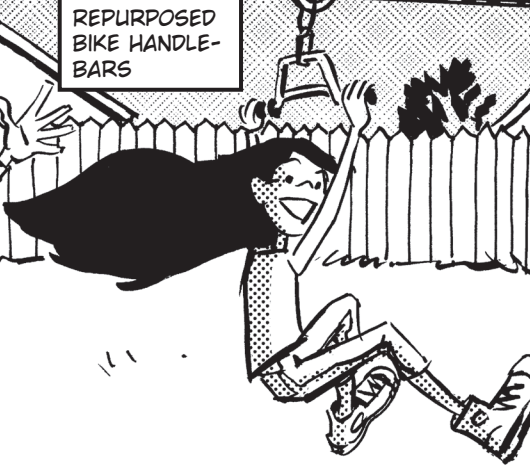
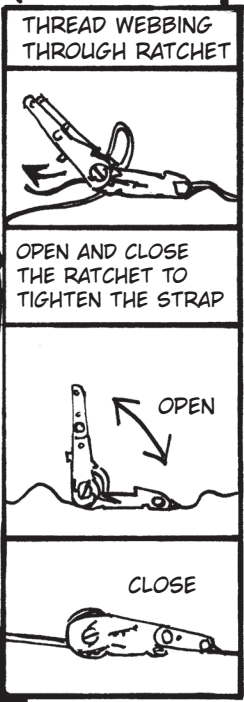
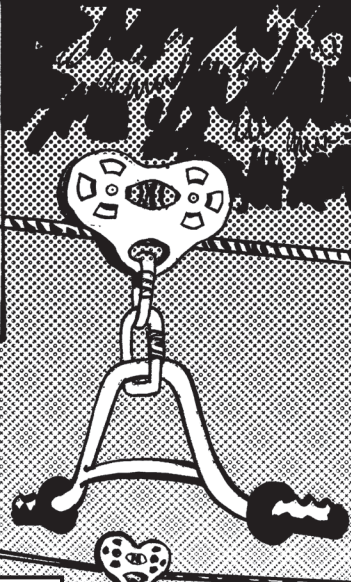
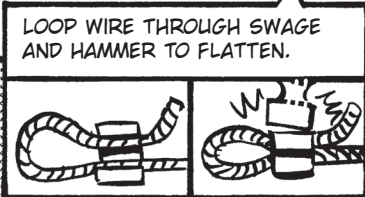
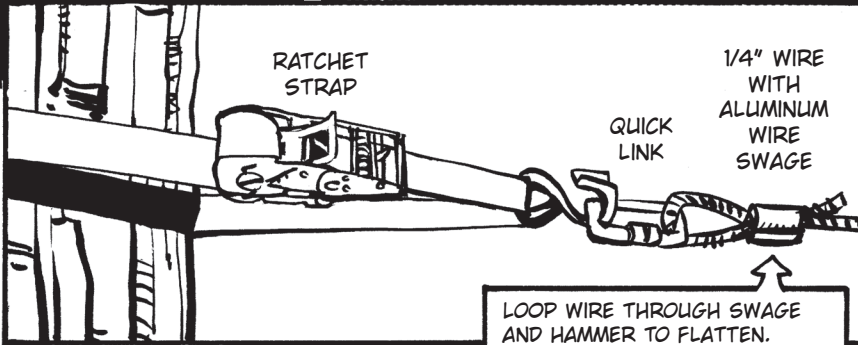

PLANT STAKE FOR GROUND ANCHOR SO BUNGEE STRETCHES TO SLOWLY STOP THE PULLEY

TREES ARE A GOOD SUPPORT FOR THE ZIPLINE BECAUSE THE WEIGHT GETS DISTRIBUTED THROUGH THE ROOTS MAKING THE ANCHORS STURDY AND SECURE.

FOR A SAFE SPEED, MAKE THE DECLINE 3 FEET FOR EVERY 50 FEET OF LENGTH.



USE 3 CABLE CLAMPS SPACED 3" APART TO CREATE A LOOP AND DOUBLE THE CABLE BACK ON ITSELF. THE BOLTS SHOULD ALL FACE THE LIVE END OF THE CABLE.

LIVE (LONG) END



DEAD (SHORT) END

WOOD STOPPING BLOCK

BUNGEE CORD

DRILL A 5/16" HOLE IN TOP OF THE BLOCK

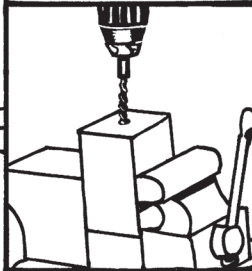

DRILL A 1/4" HOLE TO THE SIDE OF THE BLOCK

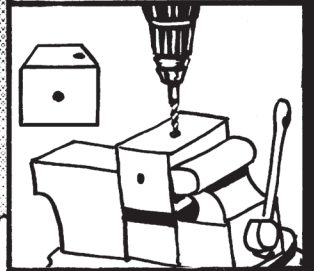

INSERT EYELET BOLT INTO THE SIDE HOLE

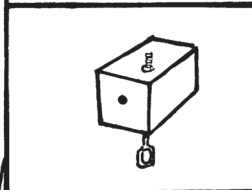

THREAD CABLE WIRE THROUGH THE BLOCK

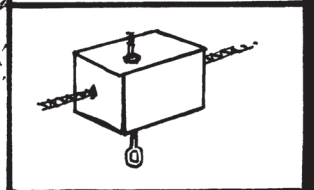

TIE BUNGEE TO BOLT USING A FIGURE-8 KNOT

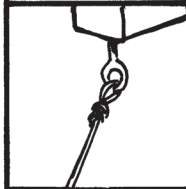

TIE BUNGEE TO STAKE USING A FIGURE-8 KNOT



DRIVE STAKE IN WITH Mallet

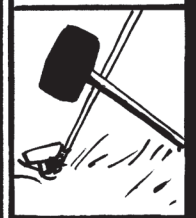

HAMMER TIME

HIT THE NAIL ON THE HEAD!

THE HAMMER IS A TOOL MEANT TO DELIVER FORCE. ALWAYS WEAR YOUR SAFETY GLASSES!

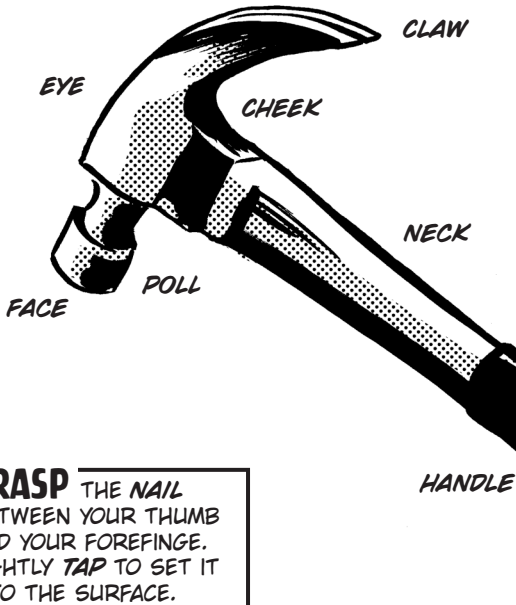

REMOVING NAILS SLIDE THE CLAW UNDER THE NAIL AND PULL THE HAMMER TOWARDS YOU TO EXTRACT THE NAIL.

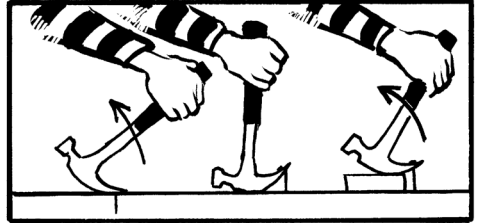

GRASP THE NAIL BETWEEN YOUR THUMB AND YOUR FOREFINGER. LIGHTLY TAP TO SET IT INTO THE SURFACE.

HOLD THE HAMMER NEAR THE END OF THE HANDLE WITH A FIRM GRIP. THIS WILL GIVE YOU MORE POWER WHEN SWINGING.

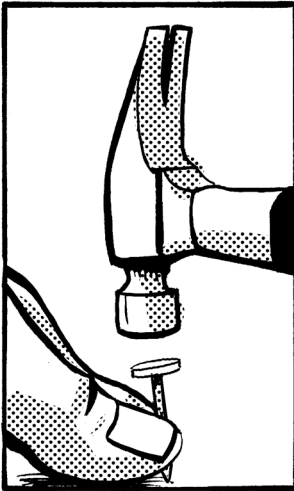

SWING USING YOUR WHOLE ARM AND ELBOW AND LET THE WEIGHT OF THE HAMMER BE THE FORCE.

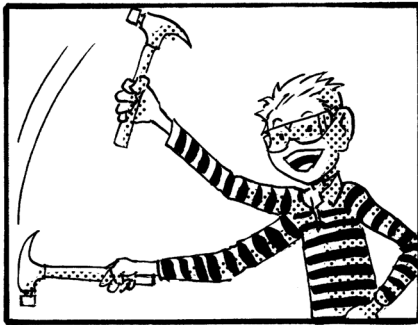

CONTACT THE NAIL HEAD SQUARELY WITH THE HAMMER.

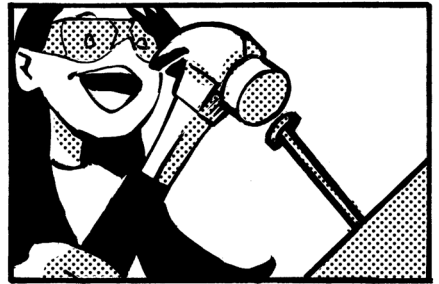

BASIC CLAW

FOR POUNDING NAILS. THE CLAW PART IS USED FOR PULLING NAILS OUT.

BALL PEEN

FOR DRIVING A CHISEL OR A PUNCH.

MALLET

FOR DELICATE WORK WITH WOOD AND METAL.

STONE MASONRY

FOR CHIPPING AND CHISELING STONE, BRICK, AND CONCRETE.

LIGHTWEIGHT

FOR SMALL PROJECTS AND CRAFTS.

CUT TO THE POINT

CUTTING

DOVETAIL SAWS



CLEAN, STURDY CUTS, GREAT FOR FRAMES CABINETS AND TOYS.

BACK SAWS



THICK BLADED WITH REINFORCED BACK FOR PRECISION CUTS.

BOW SAWS



STEEL FRAME AND BLADE FOR ROUGH-CUTS OF WOOD.

CROSSCUT SAWS



FOR CUTTING AGAINST THE GRAIN. CAN BE USED FOR MANY PURPOSES FROM LOGGING TO DETAILED CARPENTRY.

RIP SAWS



FOR CUTTING WITH THE GRAIN. THE RIPPING ACTION OF THE SAW PRODUCES A COARSE RAGGED CUT WHICH MAKES THE SAW UNSATISFACTORY TO FINISH.

COMPASS SAWS



SMALL BLADE USED FOR CUTTING CURVED OR STRAIGHT HOLES.

KEYHOLE SAWS



INTRICATE CLOSE INSIDE WORK FOR SPECIALTY JOBS.

COPING SAWS



CUTS IRREGULAR SHAPES AND INTRICATE PATTERNS.

THIS IS THE CORRECT CUTTING POSITION. YOUR VISION SHOULD ALWAYS BE TRUE TO THE CUTTING PLANE AND ALWAYS KEEP A STRAIGHT LINE OF ACTION!

IF POSSIBLE USE A CLAMP OR A VISE TO HOLD YOUR PIECE AND STOP VIBRATION.

LINE OF ACTION

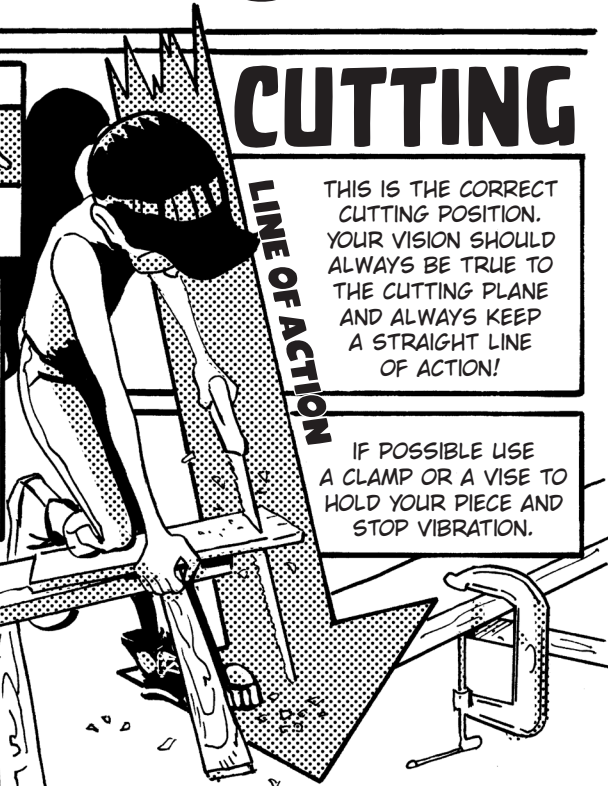

CROSS CUT TEETH

CROSSCUT TEETH ARE SMALL TEETH USED TO SEVER WOOD WHEN CUTTING ACROSS THE GRAIN.

RIP TEETH

RIP TEETH ARE MEDIUM-SIZED TEETH DESIGNED TO SCOOP OUT WOOD FIBERS WHEN CUTTING WITH THE GRAIN.

ALWAYS PROTECT YOUR EYES!

1" 4 T.P.I.

T.P.I. STANDS FOR TEETH PER INCH! RULE OF THUMB: THE MORE T.P.I. THE HARDER THE MATERIAL THE SAW CAN CUT!



THE HACKSAW

MOST VERSATILE OF ALL SAWS
CUTS PLASTIC / METAL / WOOD

UPKEEP A LIGHT COATING OF OIL WILL MAKE BLADES LAST LONGER. BE CAREFUL NOT TO BEND YOUR SAWS. HANGING THEM UP IS A GOOD METHOD FOR STORAGE.



USE A MITER BOX!

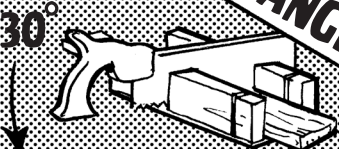

SEE SAW

A SEE SAW IS A **LEVER**. THE LONG BOARD THAT HINGES ON A **PIVOT POINT** OF THE LEVER CALLED A **FULCRUM**. ALLOWING YOU TO LIFT OBJECTS THAT ARE MUCH HEAVIER THAN YOU COULD LIFT YOURSELF.

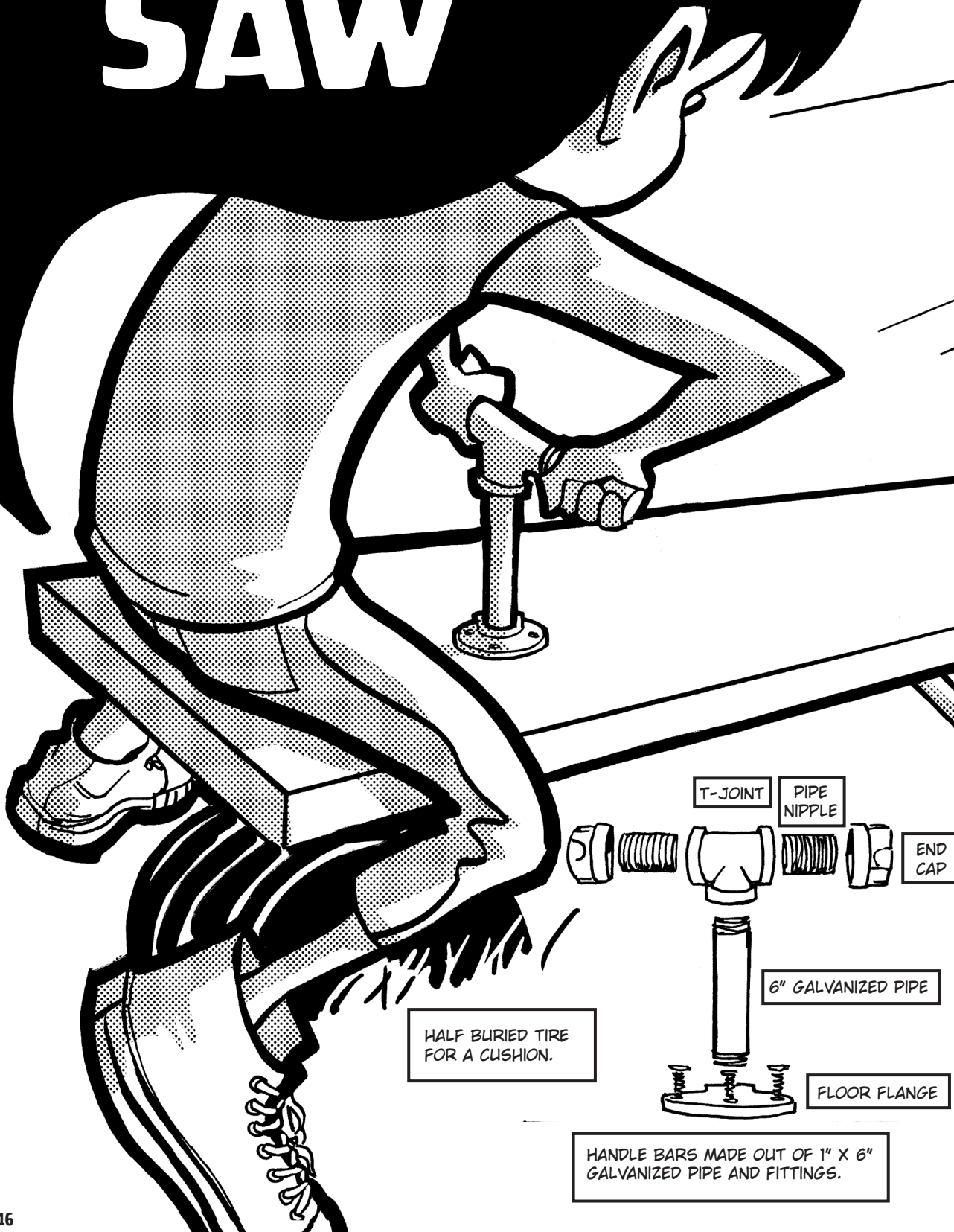

HALF BURIED TIRE FOR A CUSHION.

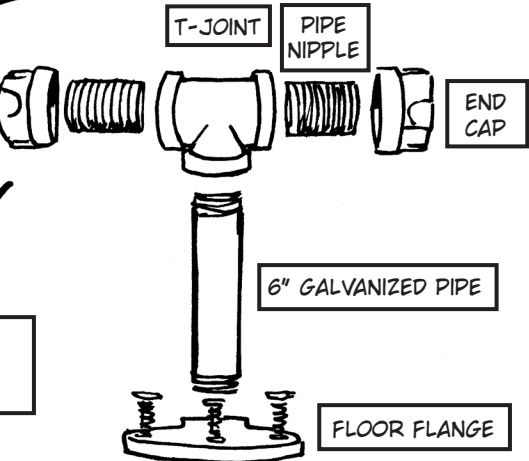

HANDLE BARS MADE OUT OF 1" X 6" GALVANIZED PIPE AND FITTINGS.

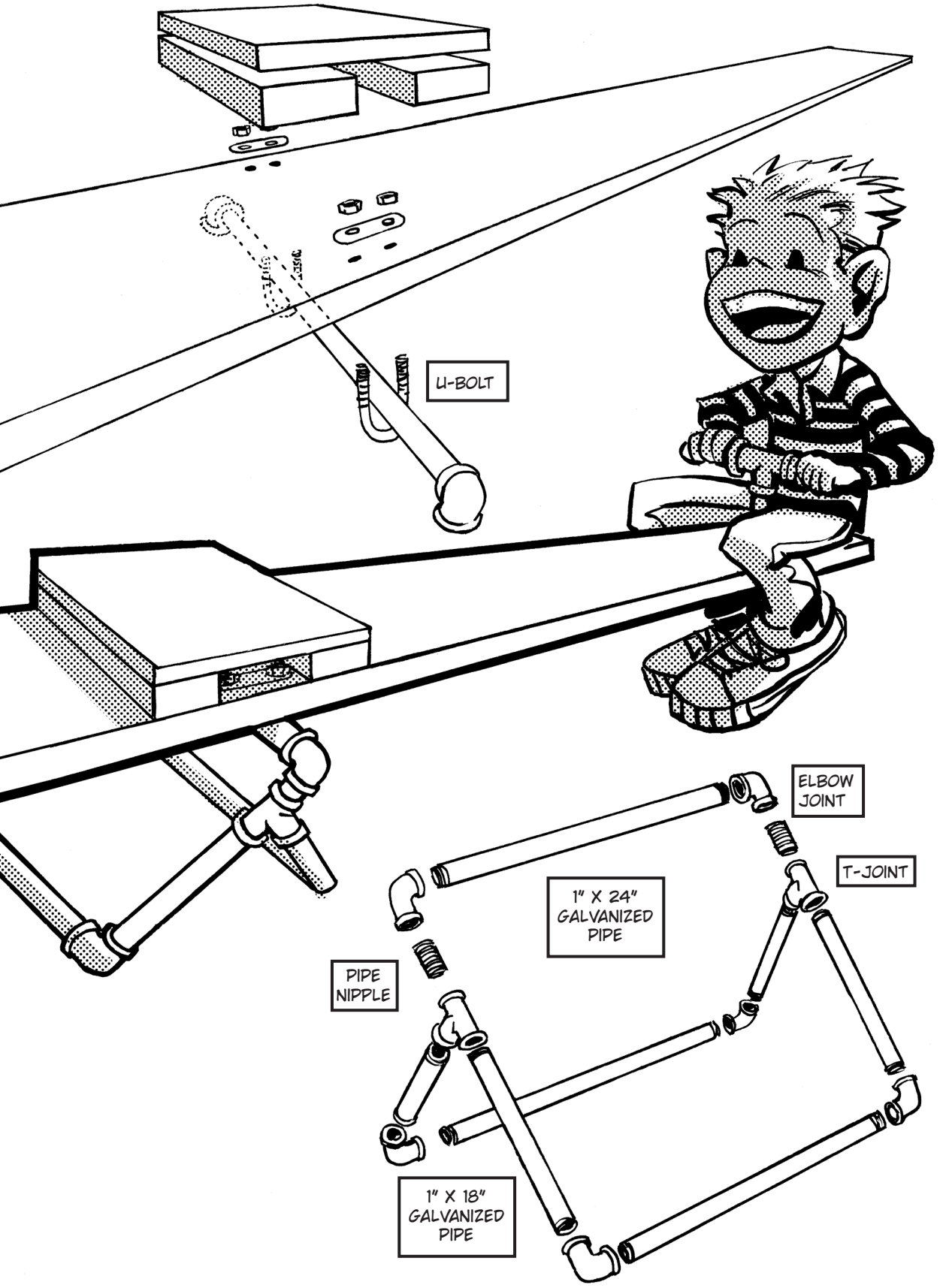

LET'S BREAK
NEW GROUND!

SHOVELING 101

WE'RE GOING
TO USE THE
EARTH ITSELF
TO KEEP THIS
PLAYGROUND
STEADY.

A SHOVEL
CONCENTRATES A
MAXIMUM AMOUNT
OF FORCE INTO A
SMALL AREA.

FIRST WE NEED
TO HARNESS THE
BASIC TOOLS OF
EARTH MOVING.

SET THE SPADE AT
THE POINT YOU WANT
TO DIG AND EXTEND
YOUR ARMS.

HOP UP ONTO THE SHOVEL
USING YOUR WEIGHT TO
BREAK THE GROUND.

PULL BACK AND LIFT WITH YOUR LEGS.

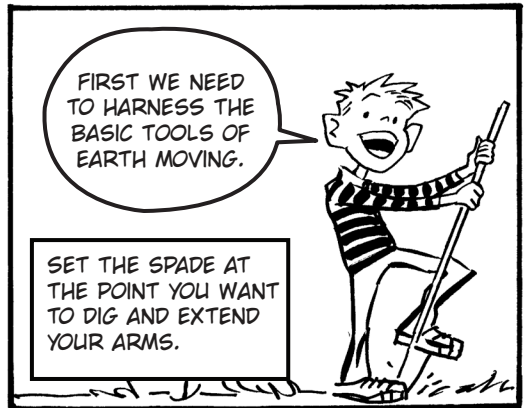

NO MATTER HOW BIG
OR SMALL THE JOB IS,
ALWAYS CHOOSE THE
RIGHT SHOVEL!



SPADE



SQUARE



SNOW

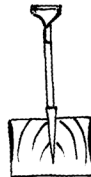

TRENCH

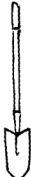

GRUB HOE



MATTOCK



TROWEL



POST HOLE



TO MAKE POSTS STURDY, YOU HAVE TO DIG DEEP FOUNDATIONS.

SURROUNDING YOUR POSTS WITH CONCRETE WILL MAKE A **HEAVY** BASE THAT KEEPS THEM UPRIGHT AND **SOLID**.

YOU HAVE TO LET THE CONCRETE SET UP BEFORE DOING MORE WORK ON YOUR PROJECT!

REFER TO THE INSTRUCTIONS ON THE BAG- CEMENT MIXED WITH MORE WATER REQUIRES LONGER TIME TO HARDEN.

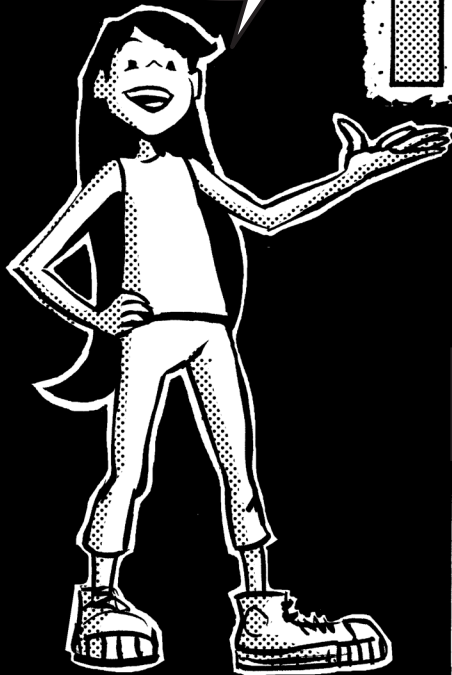

MIX THE WATER, GRAVEL, AND CEMENT **REALLY CLOSE** TO WHERE YOU'RE GOING TO POUR IT! IT'S **HEAVY!**



CONCRETE IS A MIXTURE OF **AGGREGATE** (SAND, GRAVEL OR CRUSHED STONE) AND **BINDER**, WHICH IS THE CEMENT (HEATED LIMESTONE AND CLAY).

WHEN YOU ADD WATER TO THIS DRY MIX, IT BONDS THE COMPONENTS TOGETHER IN A PROCESS CALLED **HYDRATION**.

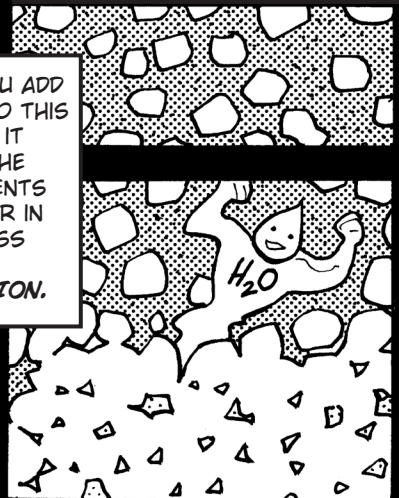

YOU MUST MIX THE PROPORTIONS OF STONE, CEMENT, AND WATER TO MAKE THE WET CONCRETE **WORKABLE** TO FILL A FORM (SAY, YOUR HOLE) SOLIDLY.



THIS IS OLD SCIENCE, BY THE WAY. ANCIENT ROMANS BUILT ROADS AND TEMPLES WITH CONCRETE THOUSANDS OF YEARS AGO!

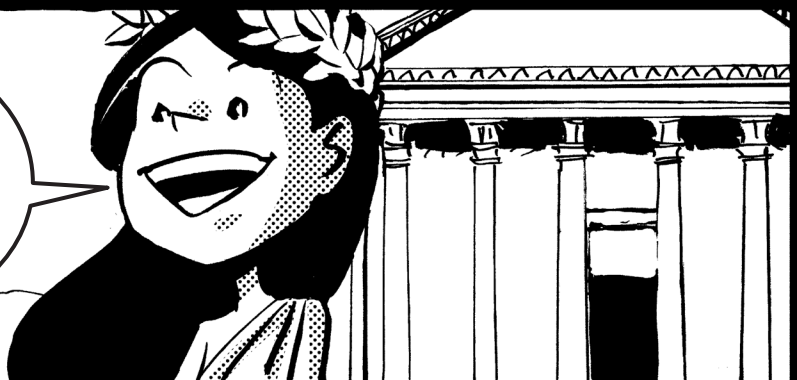

MONKEY BARS!

1 STEP

MATERIALS:

- (4) 4"X4"X10'
- (2) 2"X6"X10'
- (2) 2"X4"X8'
- (9) 20" 1" GALVANIZED METAL PIPE
- EPOXY ADHESIVE
- (24) 3 1/2" WOOD SCREWS
- (8) CARRIAGE BOLTS
- PREMIXED BAGGED CONCRETE
- MULCH

TOOLS:

- DRILLS AND BITS
- MALLET
- LEVEL

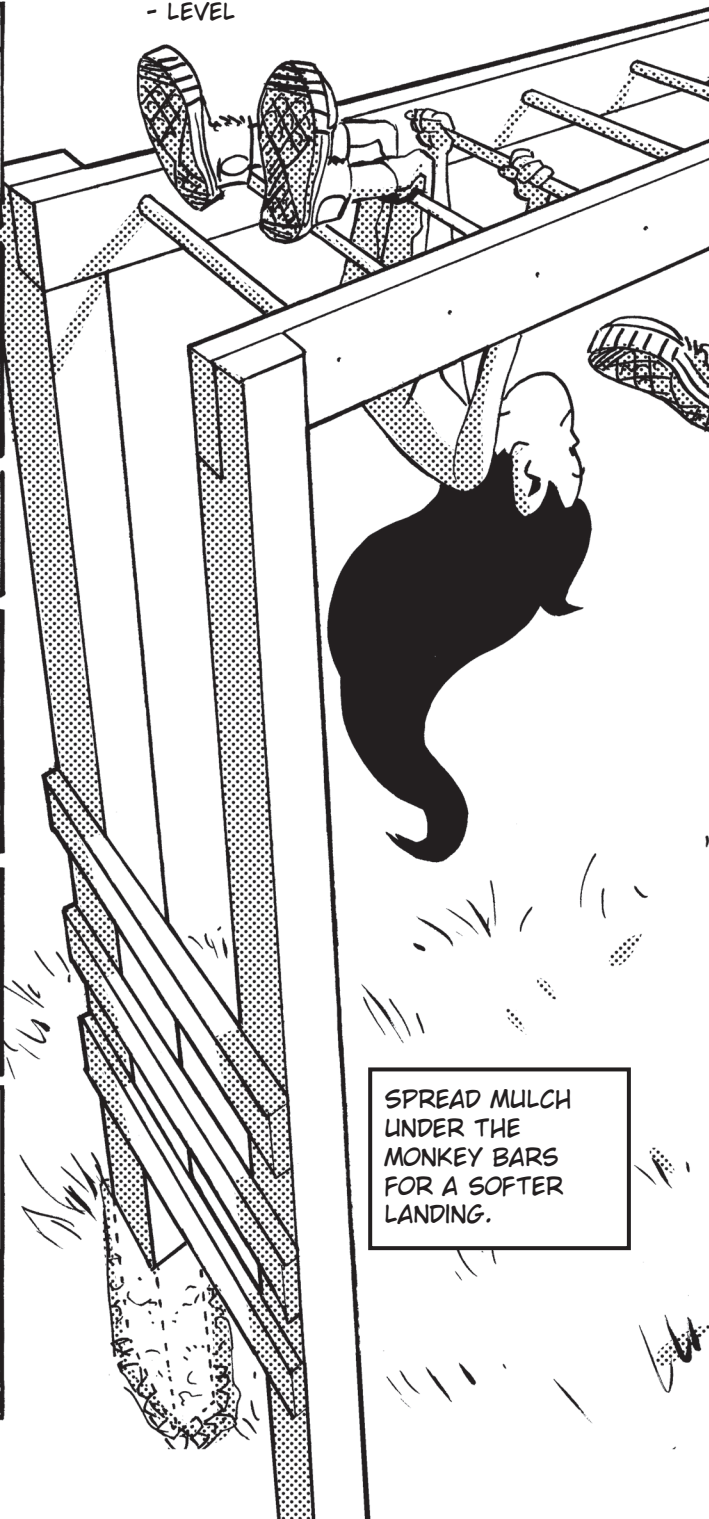
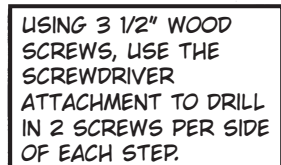
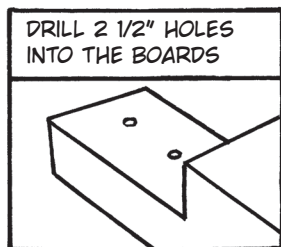
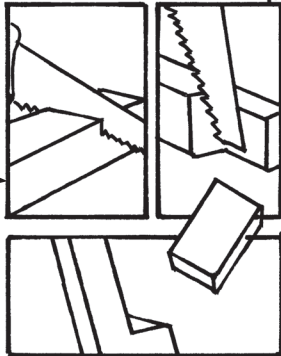
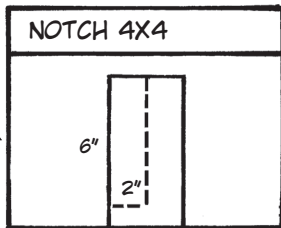

SPREAD MULCH UNDER THE MONKEY BARS FOR A SOFTER LANDING.

USE A LEVEL TO MAKE SURE THE LADDER IS STRAIGHT.

2 MONKEY BARS

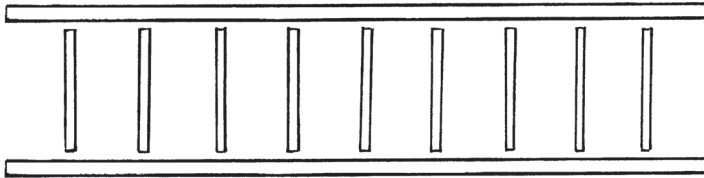

USING A 1 1/2" HOLE SAW, DRILL STRAIGHT DOWN INTO THE MARKED SPOTS.

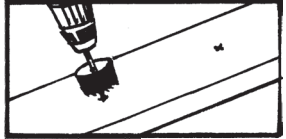

DRILL DOWN UNTIL THE END OF THE DRILL GOES THROUGH THE OTHER SIDE. ABOUT 1/2" FROM BOTTOM.

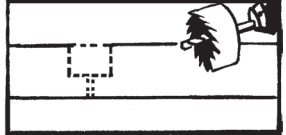

EPOXY BOTH ENDS AND INSERT THE METAL RINGS INTO THE WOOD.

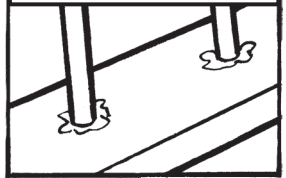

3 ATTACH

USING CARRIAGE BOLTS, ASSEMBLE THE MONKEY BARS TO THE FOUR POSTS. COUNTERSINK THE POST.

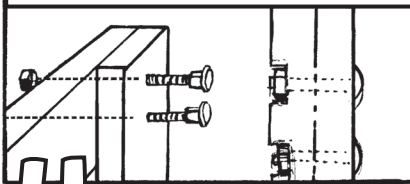

4 FOUNDATION

USING A POST HOLE DIGGER, DIG 4 HOLES 4 FEET DEEP INTO THE GROUND.

POUR GRAVEL INTO EACH OF THE 4 HOLES, TO HELP EVEN OUT THE SURFACE.



USING A Mallet, BANG THE METAL RINGS TO FIT.

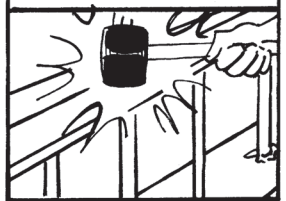

AFTER THE MONKEY BARS ARE FULLY SET, DO A SAFETY INSPECTION AND CHECK THAT EVERYTHING IS SECURE.



5

LINE THE FRONT POLES WITH THE FRONT HOLES AND LET THE POSTS SLIDE INTO PLACE.



6 SET

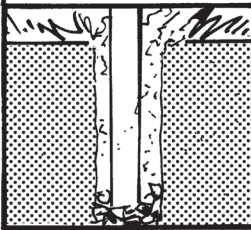

USE PREMIXED CONCRETE FROM THE HARDWARE STORE AND FOLLOW PACKAGE INSTRUCTIONS.

LIFT

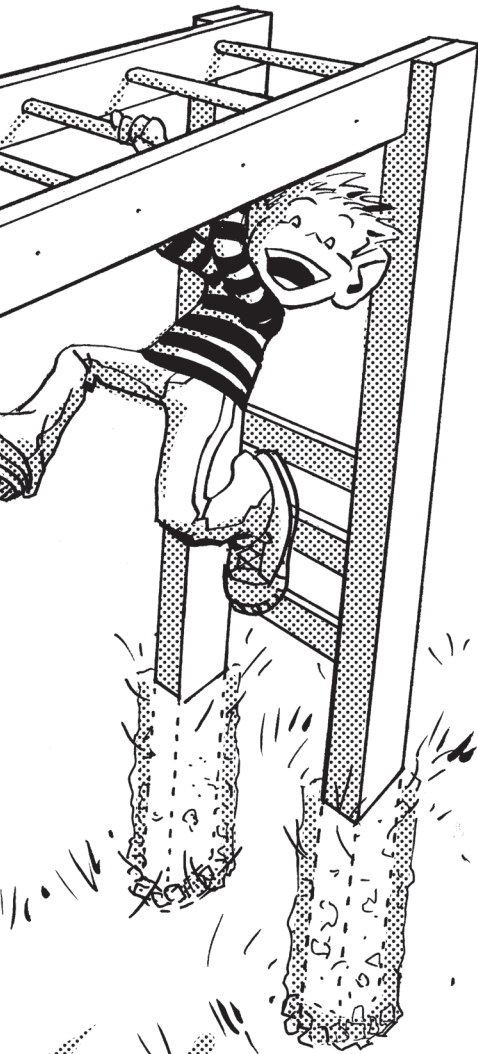

ROPE LADDER

NOW THAT OUR MONKEY BARS ARE BUILT LET'S ADD A LADDER!

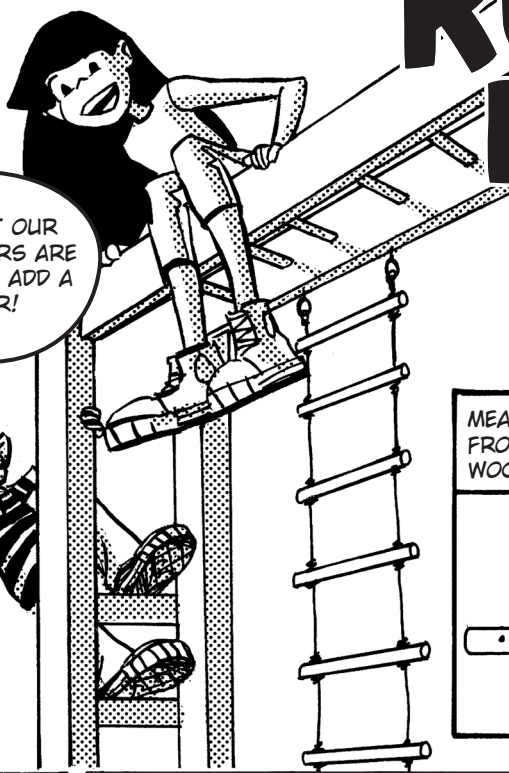

MATERIALS:

- 24 FEET OF 1/4" ROPE
- (8) 18"x1 1/2" HARDWOOD
- WOODEN RODS
- (2) EYELET SCREWS
- DUCT TAPE

MEASURE AND MARK 2" FROM EACH END OF THE WOODEN RODS.

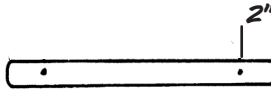

DRILL 1/4" HOLE IN EACH END OF THE RODS.

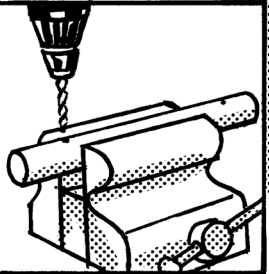

WRAP BOTH ENDS OF ROPE TIGHTLY WITH DUCT TAPE.

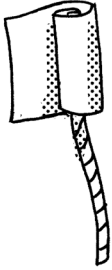

TIE A DOUBLE OVERHAND STOPPER KNOT.

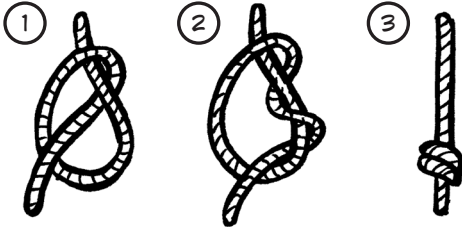

TIE KNOTS SO THAT THE CENTER OF THE RODS ARE 12" APART.

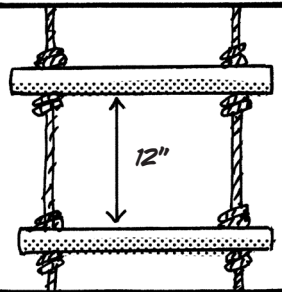

LET'S CONNECT THE LADDER USING A SCAFFOLD KNOT.

TIE A SCAFFOLD KNOT

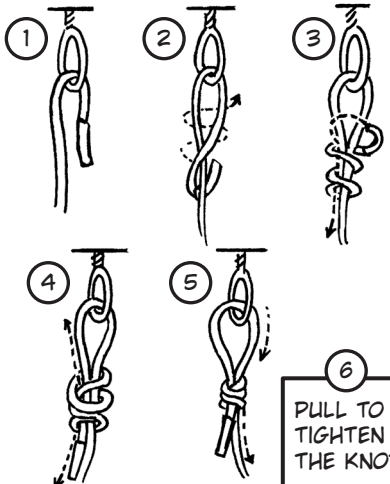

SECURE BOTTOM OF THE LADDER USING STAKES.

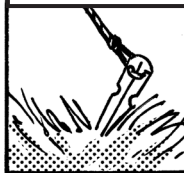

PULL TO TIGHTEN THE KNOT



OPENING DAY!

NEVER...
BEEN..

...SO...
SORE!

NOT
SURPRISED, YOU
KIDS DID A LOT
OF WORK.

THIS WAS
THE BIGGEST
PROJECT YET.

I FEEL LIKE I
HAVE A ZILLION
NEW SKILLS NOW.

YOU CERTAINLY
DO, AFTER MAKING
A SEE-SAW, A ZIP
LINE...

LEVERS.
FULCRUMS.

... HYDRATION
AND FORCE...

...ANCHORING.
...SUPPORT...
FOUNDATIONS.

YOU CAN BOTH BE
PROUD. FINISHING A
PROJECT IS REWARDING
AND FUN.

SPEAKING
OF FUN...!

NOW IT REALLY
BEGINS- COME
ON, TUCKER!



WOO
HOO!

IT'S TIME
TO PLAY ON THE
PLAYGROUND!!!

IT'S EVEN
BETTER THAN WE
IMAGINED!

WAIT FOR
US!

THE END-
(OF PLAYING
IN THE STREET!)